

# LF24-ECON-R03 US - Damper Actuator

Modulating, Spring Return, 24 V, Economizer, 3kΩ Mixed Air Sensor,  
Built-in Minimum Position Adjustment



## Technical Data

Power Supply	24 VAC, ±20%, 50/60 Hz, 24 VDC, ±10%
Power Consumption Running	2.5 W
Power Consumption Holding	1 W
Transformer Sizing	5 VA (class 2 power source)
Shaft Diameter	3/8" to 1/2" round, centers on 1/2"
Electrical Connection	3ft [1m], 18 GA plenum cable with 1/2" conduit connector
Overload Protection	electronic throughout 0° to 95° rotation
Electrical Protection	actuators are double insulated
Operating Range Y	3 kΩ NTC, 3 kΩ @ 77°F (25°C) MA setpoint = 55°F
Input Impedance	100 kΩ
Feedback Output U	DC 2...10 V, Max. 0.7 mA
Angle of Rotation	Max. 95°, adjustable with mechanical stop
Torque motor	35 in-lbs [4 Nm]
Direction of Rotation (Motor)	reversible with built-in switch
Direction of Rotation (Fail-Safe)	reversible with CW/CCW mounting
Position Indication	visual indicator, 0° to 95° (0° is full spring return position)
Running Time (Motor)	95 sec constant, independent of load
Running Time (Fail-Safe)	<25 sec @ -4°F to 122°F [-20°C to 50°C], <60 sec @ -22°F [-30°C]
Override Control	Minimum, Open, Closed via spring Min-position adjusts on actuator cover between 0 and 100% (scaled 0 to 1)
Ambient Humidity	max. 95% RH non-condensing
Ambient Temperature	-22...122 °F [-30...50 °C]
Storage Temperature	-40...176 °F [-40...80 °C]
Degree of Protection	IP54, NEMA 2
Housing Material	zinc coated steel
Agency Listings†	cULus acc. To UL 873 and CAN/CSA C22.2 No. 24-93
Noise Level (Motor)	<30 dB (A)
Noise Level (Fail-Safe)	<62 dB (A)
Servicing	maintenance free
Quality Standard	ISO 9001
Weight	3.43 lb [1.56 kg]

†Rated Impulse Voltage 800V, Type of action 1.AA, Control Pollution Degree 3

**Torque min. 35 in-lb, for control of air dampers, Built-in adjustable min-position, Integrated mixed air PI-control.**

## Application

For fail-safe, modulating control of mixed air setpoint on economizer dampers in HVAC systems. Actuator sizing should be done in accordance with the damper manufacturer's specifications. The actuator is mounted directly to a damper shaft from 3/8" up to 1/2" in diameter by means of its universal clamp, 1/2" shaft centered at delivery. For shafts up to 3/4" use K6-1 accessory. A crank arm and several mounting brackets are available for applications where the actuator cannot be direct coupled to the damper shaft. The actuator operates in response to 3 kΩ thermistor, which allows the LF24-ECON... to retrofit or replace Honeywell® M7415 actuators. A 2 to 10 VDC feedback signal is provided for position indication.

## Operation

The LF series actuators provide true spring return operation for reliable fail-safe application and positive close-off on air tight dampers. The spring return system provides constant torque to the damper with, and without, power applied to the actuator. The LF series provides 95° of rotation and is provided with a graduated position indicator showing 0 to 90°. The LF24-ECON-R03 US uses a brushless DC motor which is controlled by an Application Specific Integrated Circuit (ASIC) and a microprocessor. The microprocessor provides the intelligence to the ASIC to provide a constant rotation rate and to know the actuator's exact position. The ASIC monitors and controls the brushless DC motor's rotation and provides a digital rotation sensing function to prevent damage to the actuator in a stall condition. The actuator may be stalled anywhere in its normal rotation without the need of mechanical end switches. Power consumption is reduced in holding mode. See wiring diagrams for LF24-ECON-R03 US for more details on 3-position control.

## Dimensions (Inches[mm])

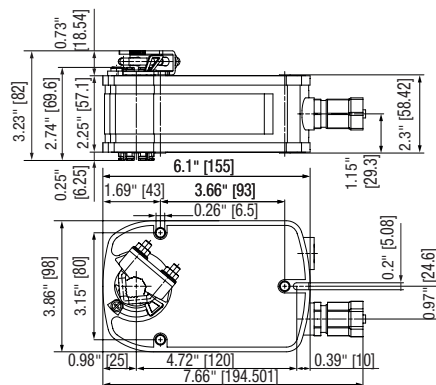

Accessories	
20477-00001	Honeywell logic module bracket.
AV6-20	6.7" shaft extension for 1/4" to 3/4" diameter shafts.
K6 US	Standard LF clamp (3/8" to 1/2").
K6-1	LF clamp (1/2" to 3/4").
KG10A	Ball joint for 3/8" diameter rod, zinc plated.
KG8	Ball joint for 5/16" diameter rod, 90°, galvanized steel.
KH8	Univ. crankarm, slot 21/64" w, for 3/8" to 11/16" dia. shafts.
KH-LF	LF crankarm (with 1/2" diameter shaft pass through).
KH-LFV	V-bolt Kit for KH-LF.
LF-P	Anti-rotation bracket LF.
SH10	Push rod for KG10A ball joint (36" L, 3/8" diameter).
SH8	Push rod for KG6 & KG8 ball joints (36" L, 5/16" diameter).
TOOL-06	8 mm and 10 mm wrench.
ZDB-LF	Angle of rotation Limiter for LF.
ZF8-LF	8x8 mm form fit adaptor for LF.
ZG-109	Right angle bracket for ZS-260.
ZG-110	Stand-off bracket for ZS-260.
ZG-112	LF right angle bracket (4-1/2" H x 5-1/2" W x 2-1/2" D).
ZG-DC1	Damper clip for damper blade, 3.5" width.
ZG-DC2	Damper clip for damper blade, 6" width.
ZG-LF112	LF crankarm adaptor kit (includes ZG-112).
ZG-LF2	LF crankarm adaptor kit (T bracket included).
ZG-LMSA-1	Shaft extension for 3/8" diameter shafts (4" L).
ZG-LMSA-1/2-5	Shaft extension for 1/2" diameter shafts (5" L).
ZS-100	Weather shield - galvanneal (13" L x 8" W x 6" D).
ZS-101	Base plate for ZS-100.
ZS-150	Weather shield - PC w/ foam seal (16" L x 8-3/8" W x 4" D).
ZS-260	Explosion proof housing.
ZS-300	NEMA 4X, 304 stainless steel enclosure.
ZS-300-5	NEMA 4X, 316L stainless steel enclosure.
ZS-300-C1	1/2" shaft adaptor, standard with ZS-300(-5).
ZS-300-C2	3/4" shaft adaptor for ZS-300(-5).
ZS-300-C3	1" shaft adaptor for ZS-300(-5).
IRM-100	Input rescaling module for modulating actuators.
P475	Shaft mount, non-Mercury aux. switch for 1/2" dia. shafts.
P475-1	Shaft mount, non-Mercury aux. switch for 1" dia. shafts.
PS-100	Actuator power supply and control simulator.
SGA24	Positioners suitable for use with the modulating damper actuators LM..A-SR, NM..A-SR, SM..A-SR and GM..A-SR
SGF24	Positioners suitable for use with the modulating damper actuators LM..A-SR, NM..A-SR, SM..A-SR and GM..A-SR
ZG-SGF	Mounting plate for SGF.
ZG-X40	120 to 24 VAC, 40 VA transformer.

### Typical Specification

Spring return control damper actuators shall be direct coupled type which require no crank arm and linkage and be capable of direct mounting to a shaft up to a 3/4" diameter and center on a 1/2" shaft (default). Actuator shall deliver a minimum output torque of 35 in-lbs. The actuator must provide modulating damper control in response to a 3 kΩ NTC thermistor, 55°F setpoint. Actuator must have a built-in minimum position potentiometer. Actuator must have a minimum position override via 0 to 10 VDC on wire 4. Actuators shall use a brushless DC motor controlled by a microprocessor and be protected from overload at all angles of rotation. Run time shall be independent of torque load. A 2 to 10 VDC feedback signal shall be provided for position feedback. The actuator must be designed so that they may be used for either clockwise or counter clockwise fail safe operation. Actuators shall be cULus listed, have a 5 year warranty, and be manufactured under ISO 9001 International Quality Control Standards. Actuators shall be as manufactured by Belimo.

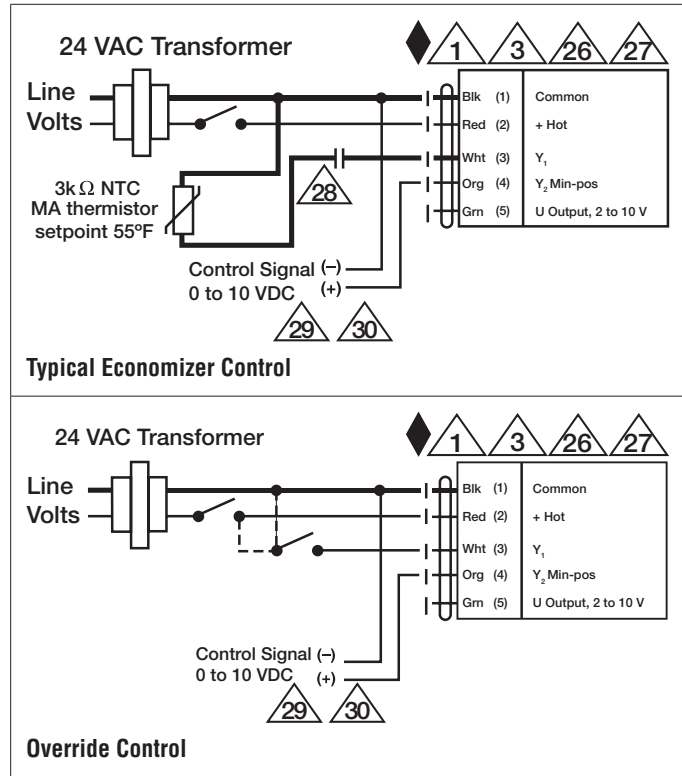

# LF24-ECON-R03 US - Damper Actuator

Modulating, Spring Return, 24 V, Economizer, 3k $\Omega$  Mixed Air Sensor,  
Built-in Minimum Position Adjustment



## Wiring Diagrams



### **WARNING! LIVE ELECTRICAL COMPONENTS!**

During installation, testing, servicing and troubleshooting of this product, it may be necessary to work with live electrical components. Have a qualified licensed electrician or other individual who has been properly trained in handling live electrical components perform these tasks. Failure to follow all electrical safety precautions when exposed to live electrical components could result in death or serious injury.



Meets cULus requirements without the need of an electrical ground connection.



Provide overload protection and disconnect as required.



Actuators may also be powered by 24 VDC.



Min-position is adjustable from 0 to 100% with a potentiometer on the actuator cover.



A relay or switch can spring return the actuator when the RTU fan de-energizes, or if low ambient temperature is sensed.



A standard relay can be used to close the sensor circuit to engage economizer mode, e.g. outside air changeover device like a dry bulb or enthalpy limit switch. Honeywell® logic module W7459A and enthalpy sensor C7400 also provide terminals for this switching.



A remote CO2 sensor or DDC controller can change the standard relay opening or closing the sensor circuit. This device can be a relay or a dry bulb/enthalpy limit switch.



Override control for Y2 only accepts 0 to 10 VDC override control.